

Klaus Hünig

The Stirling Engine

Assembly Instructions

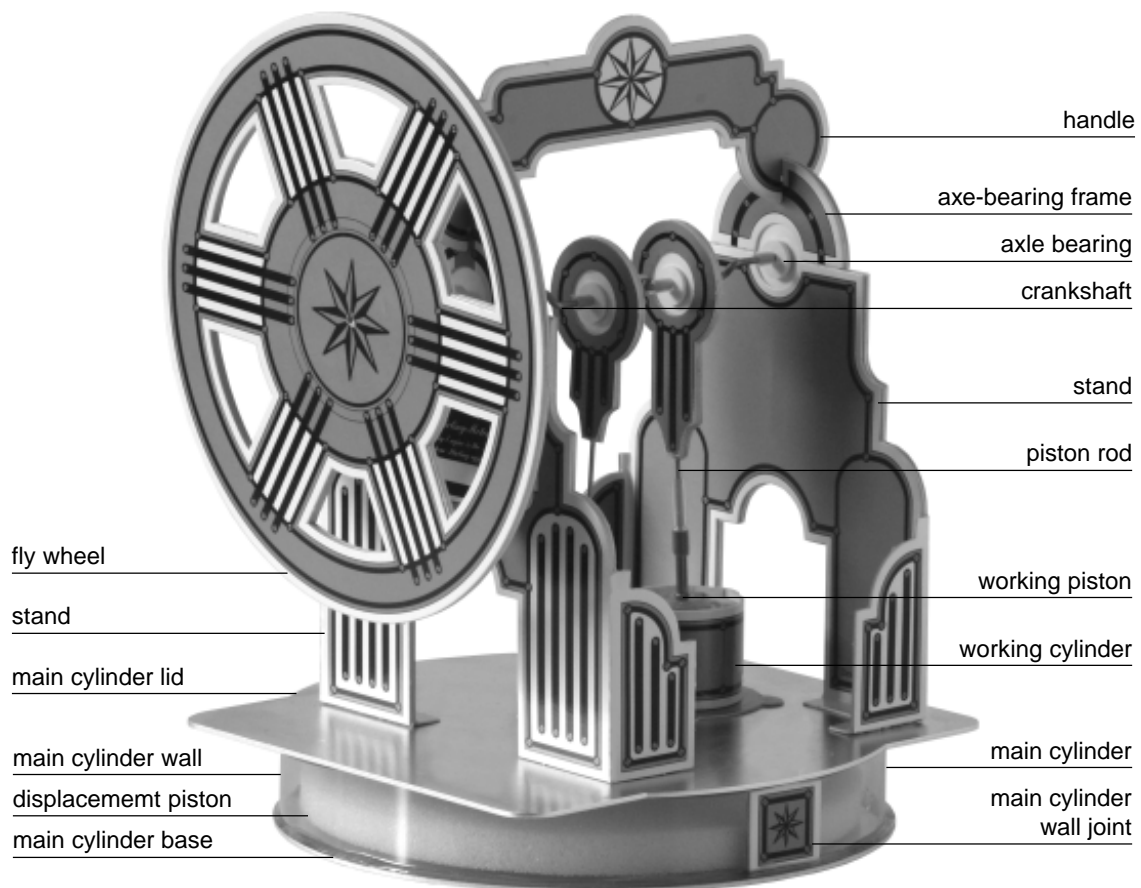

AstroMedia 

Hands-on Science Series

ISBN 3-935364-36-9 - Order No 228.STM - © Klaus Hünig - SunWatch - Design Nils Rhode



Robert Stirling

Robert Stirling (1790 – 1878) was a priest of the Presbyterian Church of Scotland with a passion for tinkering with mechanical things. He witnessed industrialization's first golden age and its ravenous hunger for energy, supplied by thousands of the steam engines James Watt had invented in 1776. Moved by pity for the victims of the countless steam boiler explosions, Stirling developed the concept of a machine that would produce energy without the use of high pressure.

On September 27th 1816 he applied for a patent on a hot air engine, which by 1818 he had perfected so far that it could be put to work in a mine in Ayrshire as a water pump. With his brother, he continued to improve his design until he reached an effectiveness of 18 % - an efficiency unheard of at the time. Robert Stirling died on June 6th 1878 at the age of 87.

At the outset of the 20th century there were about 250.000 Stirling engines in use worldwide, powering table ventilators, water pumps or small machine drives and supplying mechanical energy to private households as well as to workshops. When internal combustion engines and electric motors became increasingly popular, they gradually pushed the Stirling engine out of the market.

Today, with growing ecological conscience and ever-rising fuel costs, the undemanding and quiet Stirling engine is attracting renewed interest. More efficient, even quieter and less prone to vibrations, contemporary engines are environmentally friendly and can run on any heat source, including solar energy.

Inside the Stirling engine:

The principle is ingeniously simple and easily explained:

- In a sealed cylinder ("main cylinder"), heated or cooled at one end, a piston ("displacement piston") moves the enclosed air back and forth between the cylinder's hot and cold ends.
- In this way, the air is alternately heated and cooled, creating a cycle of compression and expansion, of high and low air pressure.
- A piston ("working piston"), connected to the main cylinder, is kept in motion by the alternating air pressure, and in turn moves a crankshaft and flywheel.
- A small portion of the produced energy is used to move the displacement piston and keep the engine running by itself.

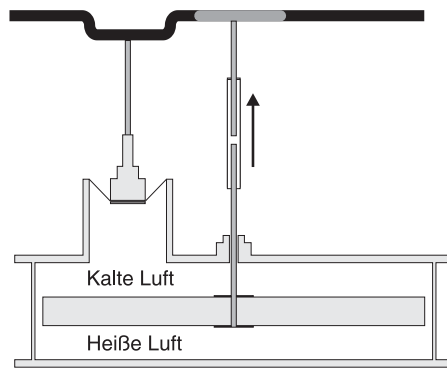

Phase 1: The displacement piston rises. The air moves from the cold to the hot segment. For an instant the outside and inside air pressures are equal. The working piston reaches its lower still point.

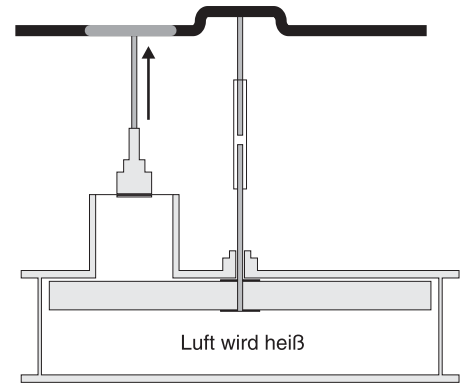

Phase 2: The displacement piston reaches its upper still point. All the air is in the hot segment, heats up and exerts pressure. The air pressure on the inside is greater than outside, forcing the working piston upwards.

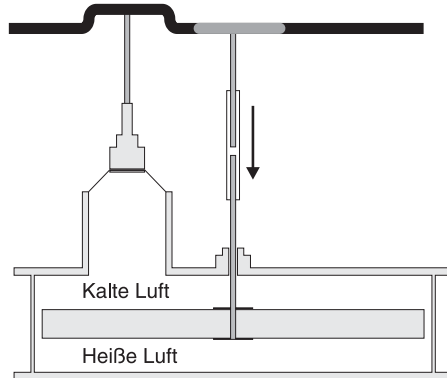

Phase 3: The displacement piston descends. The air moves from the hot to the cold segment. Outside and inside air pressure equal for an instant. The working piston reaches its lower still point.

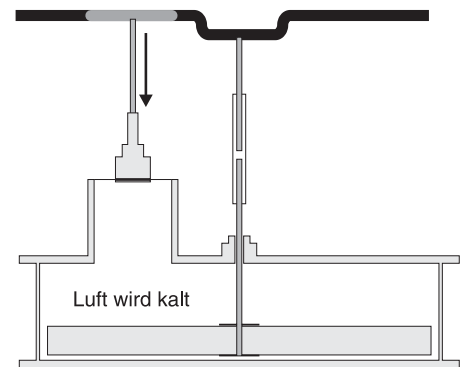

Phase 4: The displacement piston reaches its lower still point. All the air is in the cold segment, cools down and loses pressure. The air pressure outside is greater than inside, forcing the working piston down.

The AstroMedia* Stirling engine is of the flat plate type. These engines possess an extremely flat main cylinder and need only very slight differences in temperature – some can run just from body heat on the palm of your hand. This approach was first developed by Professor Ivo Kolin, University of Zagreb.

Fields of application for modern Stirling engines include, for example, solar power units - where the hot end of the main cylinder lies in the focal point of a parabolic mirror - , block type power stations for private homes, or, amazingly enough, space craft: Stirling engines produce electricity in space probes from radioactive material. They are also put to good use as reverse cycle heating systems (heat pumps) and even as cooling units: when the engine is put into motion mechanically from the outside, it transfers the heat from one side of the cylinder to the other, with either a cooling or heating effect.

Industrial Stirling engines use a so-called regenerator, which brings an additional extreme increase in performance: a wire matrix built into the displacement piston, stores excess heat from the passing hot air and returns it to the cooled-down air on its back pass.

Please read before assembly!

1. The assembly instructions are divided into many small steps. This may appear to be a lot of text, but it does make the construction understandable and leads to good results in an easy way. Please read and understand each step completely before applying it.

2. Each piece is marked with a name and a number. The sections are lettered in alphabetical order and follow the assembly process. Generally, each assembly group has its own letter. It is best to disconnect only the pieces needed at the time - or write the number on the back.

3. Avoid tearing the pieces from the cardboard; it is better to cut through the connectors with a knife, so that edges will be smooth.

4. Wherever the cardboard is to be folded, you will find little pre-punched cuts, which by themselves allow folding. The folds will turn out cleaner, though, if you press a groove into the cardboard with a ruler and some blunt-tipped instrument before folding (see the column to the right). Almost all of the perforated lines will be folded "forward"; only a few of them "backward". "Backward" means that you fold away from yourself when facing the printed side of the cardboard. "Forward" means folding toward yourself.

5. Areas marked grey indicate places on which something is to be glued. When you want small gluing surfaces to bond quickly, try this: apply glue liberally to one side, connect both surfaces for an instant so that the glue covers both equally, disconnect them and blow 2 or 3 times on both surfaces. Now press the two parts into their correct position with force – the bond holds instantly.

6. Especially the larger, flat surfaces should be gently pressed, to avoid any warping. Use a few books, on a plane surface, for example.



Things needed for assembly:

- **Two-component-glue** for attaching the transparent cylinder wall to the aluminium base and lid. A good alternative is white wood glue, though initially not transparent and taking long to set.
- A good **all-purpose glue**, best with a thin application tip for applying small glue droplets. Solvent-based glues have an advantage over water-based ones- they will not cause the cardboard to warp and will dry much quicker.
- Some fine **sandpaper** for roughening gluing surfaces and for sanding off projecting cardboard edges, if necessary.
- **Alcohol** for degreasing metal gluing surfaces.
- Light, non-resinous machine or **silicone oil** (do not use food oils!). It is a good idea to use a syringe with needle for the exact application of oil droplets.
- A **toothpick** or something similar, for applying tiny glue and oil drops accurately.
- A large **cup** of about 4" diameter, on which the main cylinder can rest during assembly.
- Small **scissors** and a **cutter** or scalpel with a thin blade for detaching pieces from the cardboard and for cutting pre-punched lines.
- A **blunt-tipped instrument** for deepening the folds. A **blunt knife** or empty **ball-point refill** will do.
- A **cutting-board** made of thick, completely flat cardboard, or of wood or plastic.
- A **set square** for checking right angles. The right-angled corner of a sheet of paper will also do.
- A large **marker pen** (about 17 mm diameter), a round wooden rod or something similar with a flat end. It will serve to bend several small cardboard pieces and also for building the latex working piston.
- A small, thin pair of **pliers** or strong tweezers for fine-tuning at the end.
- A few **paper clips** or clothes pegs, a **pencil**, some **cello tape**, a **rubber band** and a bit of thin **sewing thread**.

This kit contains:

- Four printed and pre-punched cardboard sheets, 0.5 mm thickness
- One round aluminium plate, 126 mm diameter (main cylinder base)
- One aluminium plate with two holes, 126 x 126 mm (main cylinder lid)
- Two transparent PVC strips, 0.5 mm thick, 18 mm wide (main cylinder wall)
- Two thin brass tubes, 18 mm length (casing for the displacement piston rod and mounting for the working piston rod)
- One silicone tube, 110 mm long, (connects the piston rods and holds the axle bearing discs in place)
- One latex glove (latex seals for the working piston)
- One foam disc, 113 x 8 mm with bore hole (displacement piston)
- Three bent pieces of spring steel wire, 1 mm thick, with small hook (piston rods)
- One bent steel wire, 1.5 mm thick, with two projections, length 117 mm (crankshaft)
- Four large PVC discs, with bore hole (axle bearing discs for crankshaft, displacement and working pistons)
- Eight small PVC discs, with bore hole (guide discs for axle bearing discs)

Important Notice: Like any engine, the Stirling engine must be assembled with great care to ensure its good functioning, especially since it is designed to run on the minimal heat supplied by a cup of hot water. The two most important conditions for success are that the main and working cylinders be airtight and that all moving parts run smoothly and with little friction. Please pay special attention to these two aspects.

Take plenty of time and have patience, especially with the fine-tuning after assembly is done. If you do, you will be rewarded with a beautiful model with a very long running time. Important assembly steps and tests are highlighted just like this paragraph.

Assembly

The construction consists of **64 steps**, divided into sections **A** through **O**:

Section A:

The Flywheel

Even though the flywheel will be attached to the engine only at the very end, it is needed for the gluing of the main cylinder wall right at the outset.

Step 1: Mark a vertical pencil line on the grey front of the two centre pieces of the flywheel (A1) and (A2) and on the white back of the outer and inner pieces, (A3) and (A4). Now separate the pieces from the cardboard sheet and remove the superficial material between the spokes. Save these little pieces for fine-tuning later on (see the chapter on tuning tips).

Tip: The pencil line marks the fibre direction of the cardboard material. All paper and cardboard materials have increased flexibility in one direction and less of it when turned 90 degrees. If you take this fact into account before gluing, you can achieve a plywood-like resistance to warping in the finished flywheel.

Step 2: The crankshaft hole in the centre of the four flywheel parts is only pre-punched, because of its small diameter. Use the crankshaft to punch through the holes from behind. You can also use the cutter to deepen the cutting line by making careful incisions.

Step 3: Glue the unprinted sides of the two flywheel centre parts (A1) and (A2) together in perfect alignment, making the pencil marks run parallel - giving the two parts the same direction. After drying, the outside (A3) and the inside piece (A4) are glued onto the centre pieces – but with their pencil marks turned one spoke further. Press and allow to dry well.

Section B:

Maincylinder wall and base

The circular aluminium piece will become the base of the main cylinder, the other one the lid.

For production reasons, the metal is liable to have one good side and one with scratches. If so, simply turn the less pretty side to the inside of the cylinder during assembly. The wall of the main cylinder is made of two strips of transparent PVC, which are shaped into a ring and glued onto the base. In order to get this ring onto the metal in a perfectly round shape, the flywheel is needed.

Step 4: Remove any protective foil from the two aluminium pieces. Degrease and clean the circular aluminium base with a bit of cloth and alcohol. If you've got solar energy in mind for your engine (see section O, tuning tips), you can paint the aluminium plates

black now. Paint the outsides of the main cylinder, that is, the prettier surfaces, prevent any paint from getting into the centre hole and allow the paint to dry well.

Now lay the flywheel down in the centre of the less pretty side, which will now protrude about 3 mm on all sides. Take a thin pencil or pen and run a line along the circumference so that a circle is visible on the metal. Use sanding paper to gently roughen the metal surface both along and inside this line. This way the glue will form a stronger bond and the roughened surface will give off more heat to the air inside the cylinder. Renew the circle now. It will guide you in applying the 2-component-glue. While you are at it, also clean and degrease the other metal plate, the future lid, and the two PVC strips, the cylinder wall-to-be.

Step 5: Glue the middle piece (B2) of the cylinder wall joint on the centre of the back side of the outer piece (B1). The middle piece has the same height but only about a third of the width of the outer piece, leaving about 6 mm free on each side. Do not allow glue to run out onto this free area. Now glue the second outer piece (B3) onto the centre piece. You now have a square joint with a 6 mm deep slot on each side, where the ends of the PVC strips will fit nicely (see illustration 1). Repeat all with parts (B4), (B5) and (B6) of the second joint.

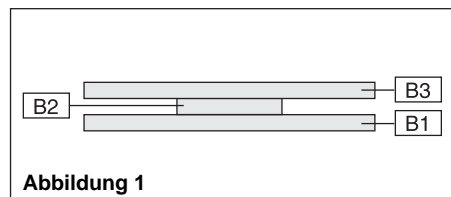

Step 6: Lightly sand the ends of the two transparent PVC cylinder wall strips at both ends, and on both sides, for a width of about 4 mm. Without this sanding, the plastic surface would be too smooth for the glue to bond well.

Tip: The next two steps are all about making the cylinder wall just large enough so that the flywheel, serving as a temporary model, will fit in tightly.

Step 7: Introduce a bit of glue into the two slots of one of the cylinder wall joints. Now insert one end of each of the two PVC strips into each of the slots to a depth of about 5 mm – not going all the way to the end – and wipe off any extra glue. You should now have the two strips connected by the joint to a total length of about 37 cm. Now glue the second joint to one of the free ends, but do not yet connect the last end to form a ring. Check that the strip runs level through all of its parts without corners at the joints by gently knocking it on a level surface with its edge. If necessary, clamp the joints with clothes pegs or paper clips and allow to dry.

Step 8: Put the flywheel on your work surface and connect the two ends of the cylinder wall without glue to form a ring. It should fit tightly around the flywheel. If need be, you can shorten the PVC strips a little. Take note of the depth to which the end of the strip needs to be inserted into the slot, so that the flywheel sits snugly and is held tight. Glue the strip into the joint without the flywheel inside. Check once more that the cylinder wall edge runs level over its complete length. Clamp the joint and allow to set.

Step 9: Push the flywheel into the cylinder wall once more so that it is held tightly. You may have to use little bits of cardboard to wedge it in place. It should rest just above the middle and should not touch either of the edges, top or bottom. The flywheel forces the wall to take on its final circular shape. The flywheel will be removed during step 13 after gluing the wall onto the cylinder base.

Step 10: On the less pretty side of the cylinder lid, stick a piece of cello tape over the small hole in the centre, then lay the base on your work surface with the cello tape facing down. Gently round one of the ends of each of the small brass tubes with sandpaper. This will facilitate slipping on the silicone tubes later on. Put one tube aside and insert the other into the hole of the cylinder lid. This will be part of the casing for the displacement piston rod. Don't glue it on yet – wait until after the next step.

Step 11: Mix a sufficient amount of 2-component-glue and apply a continuous and not-too-thin line to the main cylinder base. It should be several millimetres wide and cover both sides of the pencil marking, where the cylinder wall will rest. With the flywheel inside, set the cylinder wall on the glue line, turning it clockwise and counter clockwise a bit to ensure complete contact with the glue. Now take a close look and inspect the contact line all around the cylinder wall – if you find any gaps or insufficient amounts of glue, close them with drops of glue. If you want to be sure that the wall is sitting tightly on its base, weigh it down by carefully laying a book on top.

Test: Before putting it aside to dry, have another look to ensure that the wall has not moved and is sitting right in the centre with equal distance to the base edge all around.

Step 12: Use a toothpick to put a small amount of 2-component-glue in the corner that the brass tube forms with the cylinder lid. Turn the tube a bit and also take it up and down so that the glue covers the entire contact surface. The cello tape will keep the tube from looking out of the bottom of the lid.

Test: Before the glue sets, check that the tube is vertical with the help of a set square or a right-angled piece of paper. The tube must be at 90° on all sides. The piston rod casing has to be exactly vertical on the cylinder lid, otherwise the displacement piston in the main cylinder would not run parallel to the cylinder base and lid later on.

Step 13: After drying, remove the flywheel from the main cylinder and do another visual check: the glue should form an airtight weld between cylinder wall and base. You can now remove the cello tape from the cylinder lid and check, from above, with one of the 3 thin wire piston rods, whether it can move freely and easily within the tube. Push out any obstructing glue with the wire.

Step 14: Since it isn't needed anymore as a gluing model, we can finish constructing the flywheel now. Separate the three parts of the flywheel axle mounting (A5), (A6) and (A7) from the cardboard, deepen the fold lines marked with small cuts and fold them forward. The two very close lines are fold lines, too, and are also folded forward. The wedge-shaped mounting lashes – you can identify them by their black lines and screws – will be glued onto the flywheel later. One each of the other two lashes marked with a double line must be glued to its mate, which is part of another of the 3 mountings. In this way, you will get something like a three-pointed star, with gluing lashes, marked by a line and screw, at its lower edge (see ill. 2).



Abbildung 2

Step 15: From below, insert the long end of the crankshaft into the centre of the star, where the parallel pre-punched lines are. You are making a channel for the wire. Pull the mounting off again, insert the crankshaft from the other side and put glue on the gluing lashes. Now insert the crankshaft into the hole in the flywheel centre – on the side with markings for the mounting lashes. Next, push the mounting onto the crankshaft, against the flywheel, and glue the 3 pairs of lashes onto their marked spots. Take care that the flywheel sits at a right angle in respect to the crankshaft, so that it won't wobble later on when turning. After drying, you can remove the crankshaft. The flywheel will be attached to the engine only at the very end.

Tip: Before we complete the main cylinder, we need to assemble the displacement piston and the working cylinder along with the working piston in the next sections.

Section C:

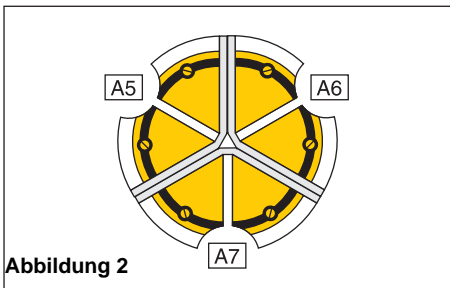
The Displacement Piston

The displacement piston consists of the foam disc, 8 mm thick, and a cardboard mounting (C1 to C14) (see ill. 3), which will fit into the hole in its centre. The mounting holds the wire piston rod.

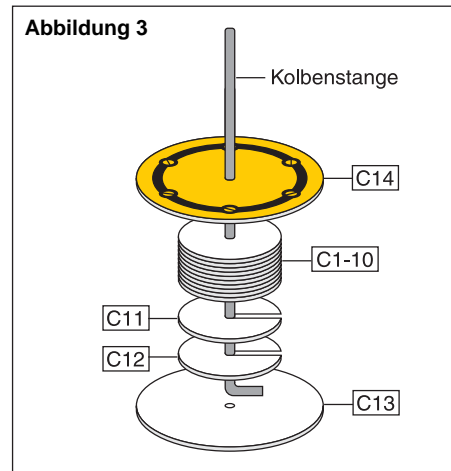

Step 16: With the end of one of the 3 piston rods, remove the cardboard bits from the hole in discs (C1) to (C10). Discs (C11) and (C12) have a partially punched slot instead of a hole, running from the centre to the edge. Cut the slot free, dislodge the cardboard bits inside and then glue all 12 pieces together, so that the two slots lie above one another at one end (see ill. 3). Continue with the next step right away.

Step 17: Before the glue sets, insert the long end of one of the piston rods into the block of cardboard discs, so that the small hook at the end rests in the slot. Glue the printed large disc (C13) right onto this slotted end of the block and centre it. The hole in the piece's centre can be ignored. Try putting the long wire end, from beneath, into the brass tube in the centre of the main cylinder lid. By moving the cardboard block back and forth, make sure that it rests flat on the metal and does not wobble when you spin the piston rod. In this way you can be sure that the piston rod is perpendicular to its mounting.

Important: The long wire end must be perpendicular to the block. The piston rod needs to stand vertically on its mounting.

Step 18: Now push disc (C14) on the piston rod without glue, as in ill. 3, and test the overall height of the cardboard mounting by putting it next to the foam disc. Height will vary depending on the glue amounts used, but it should not be higher than 7, at the most 7.5 mm – but in any case less than the 8 mm thickness of the foam. If necessary, remove the last, small cardboard disc from the block again with your knife. Then glue disc (C14) on. The foam disc will be installed on the mounting in the next step, after it has dried.

Step 19: After having set, insert the mounting into the hole in the foam disc, which will stretch to accommodate the block. The piston rod will rest in the very centre of the block now.

Test: Push the displacement piston rod into the brass tube in the cylinder lid. Turn everything vertical and spin the piston on its axis by twisting the wire rod. You will see at once whether the foam disc really is perpendicular to the piston rod, or whether it wobbles instead. If need be, make adjustments. Take this opportunity to once again check and perhaps correct the right angle between brass tube and cylinder lid.

Step 20: Remove the displacement piston from the piston rod casing and glue the cardboard mounting into place by applying a few drops of glue between the outer cardboard discs and the foam with a toothpick. Do a final check on the right angle as described above – the good functioning of the engine will, among other things, depend on it.

Step 21: Push out the cardboard bits from the holes in pieces (D1 to D12), which will be the mounting for the piston rod casing. First, glue the large disc (D1) on the cylinder lid by threading it onto the brass tube. If it does not lie flat because of the glue line at the tube's base, enlarge the hole in the disc a little. Over this, glue the rest of the larger discs (D2 to D8), and then the smaller ones (D9 to D12). A small, solid block should be the result; it stabilizes the piston rod casing.

Section D:

The Working Cylinder

You will find cylinder parts (E1 to E6) on sheet 3/4. Since sheet 4/4 has the same pressing pattern, it carries extra parts, which are not needed and marked as "reserve". If you keep them, you can use them to replace original parts in case of any damage. The working cylinder (ill. 4) consists of a small cardboard cylinder (E2, E3) on a base plate (E1). The cylinder has a doubled edge (E4), and it will be placed over the large hole in the main cylinder lid. The working piston (ill. 5) is made of a small block of cardboard discs (F1 to F10) and a latex seal cut from one of the fingers of the latex glove. The piston is glued on top of the latex seal, which is then pulled over the working cylinder and tied in place, making for airtightness and mobility at the same time. To cover the latex, the outer wall (E5, E6) will be glued around the working cylinder at the very end of assembly.

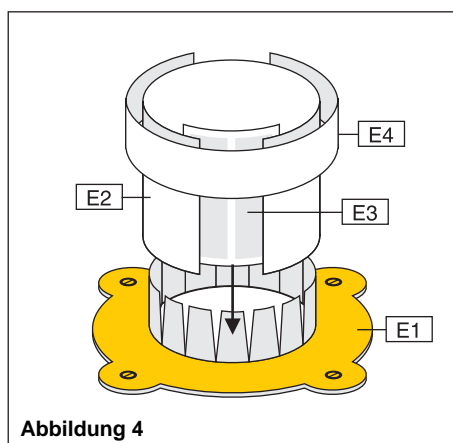

Step 22: Draw the inner wall of the working cylinder (E2) over a hard edge or wrap it around a thick pen, round stick or similar thing, bending it into a consistently round, cylindrical shape. The grey gluing area for the doubled edge faces out. Also bend the connecting piece for the inner wall (E3). Now glue the connecting piece behind both ends of the inner wall in such a way that it is hidden from view and the ends of the wall meet head-on. Carefully bend and pry the cardboard to make it round and even.

Step 23: Detach the small disc from the base of the working cylinder (E1) and fold all of the 14 inward-pointing tooth lashes forward with determination - you may have to recut some of the punched lines. Try how the cylinder wall fits on the circle of lashes, so that they are on the inside of the cylinder. The grey gluing area on the cylinder wall must be up top, not down by the lashes. Glue the wall into this position with plenty of glue.

Important: The cylinder wall should rest on its base without any gaps at all. Apply glue liberally on the lashes and in between them from inside and also to the junction of wall and base to ensure an airtight connection between the two. Allow to dry well and apply another coat of glue for good measure.

Step 24: Bend the raised edge (E4) into a consistently round shape as you did before in step 22, apply glue to one half of it and position it on the grey area on the outside of the inner wall. Don't let the end rest on the spot where the ends of the inner wall meet - the raised edge is meant to bridge this gap. Now check whether the ends meet exactly when you wrap it all the way around the wall. Cut off any overlapping cardboard carefully so that both ends meet exactly. Then glue it on. If any gaps remain, close the small ones with glue, the large ones with bits of cardboard.

Section E: The Working Piston

Step 25: Cut off the latex glove's index finger about 3.5 to 4 cm from the tip. Pull it over the end of a pencil or stick and take the latex between your fingers in such a way that it sticks out from them like a bud. Remove the pencil and cut off a bit of the latex at its top, so that you get a hole of about 4 to 6 mm diameter at the very tip of the finger.

Tip: You can make a replacement seal from the other fingers anytime. - The cardboard discs (F1, F3) have no hole. They will be glued onto the latex seal from both sides in the next steps, effectively closing the hole.

Step 26: Pull the latex seal over the smooth, blunt end of a large pen or stick of about 17 mm diameter. Hold it in place with a rubber band wrapped around it. Pull the latex seal downwards with care and on all sides until its tip, with its hole, lies smoothly on the flat end of the pen. Glue the cardboard disc (F1) on the centre of the latex finger tip. It is ok if the hole is not exactly in the very tip of the finger, the disc will cover it. Allow to dry well.

Important: The tip of the latex finger should be exactly at the top, otherwise the cardboard disc would be tilted on the seal. There should also be no glue on the latex outside of the disc. It would form a hard surface on the rubber skin and decrease its flexibility.

Step 27: Pull the latex off the pencil, turn it inside out and pull it on again so that the cardboard disc is inside now. Glue disc (F3) on disc (F1), edge to edge. Now the two discs are connected not only by the latex but also via the hole.

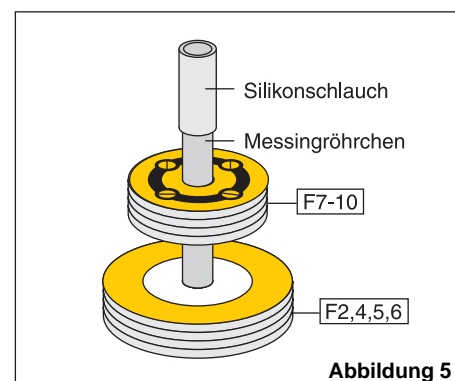

Step 28: Remove the cardboard bits from the holes of the other working piston discs by pushing through from beneath with the second small brass tube. First glue the large discs (F2, F4, F5 and last: F6) on top of each other. Then glue the smaller discs (F7, F8, F9 and last: F10), onto this block, always with the holes exactly in line. Check whether the brass tube passes all the way through the block.

Step 29: Cut off another 16 mm long piece of the silicone tube and push it about 5 mm onto the brass tube. Later on, it will serve as a joint between the working piston and the piston rod. This is easily done if you push one of the remaining wire rods through the brass tube and pull the silicone first onto this wire and then onto the brass. Then remove the wire rod and turn and pull the silicone until it is well aligned with and positioned straight on the brass tube. To be safe, clean the inside of the brass tube with the long end of the wire rod. Then glue it into the cardboard block and the whole block on the disc (F3), which is already installed on the latex seal.

The working piston is now finished and can be mounted on the working cylinder.

Section F:

Working Cylinder and Working Piston Assembly

Step 30: After it has dried well, pull the latex seal over the doubled edge (E4) around the working cylinder's opening (see ill. 6). Pull and draw the latex from all sides until the working piston with its brass tube is positioned right above the centre of the working cylinder, pointing straight up. The cardboard block of the working piston should be 6 to 8 mm above the working cylinder. Pushed into the working cylinder, it will sink for about the same distance, making for a total stroke, in this example, of 6 plus 6 = 12 mm. It can be a bit more or a bit less, but not less than 10 mm. If you hold the working cylinder horizontally above a ruler lying on your desk, and move the piston in and out, you can read off the stroke distance and correct it if necessary.

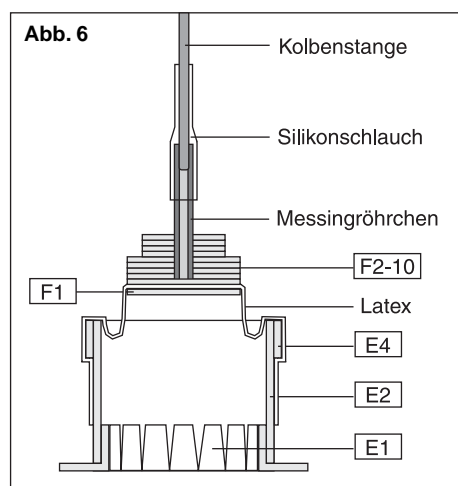

First Trial, Working Piston: Check carefully, whether the cardboard block with the brass tube moves in and out easily and without resistance. The block needs to be in the middle of the latex seal, which should be equally loose on all sides. It should not form a bulge anywhere, which would hinder the piston's movement – you can tell by its snapping sound. If this happens, try enlarging the freely moving section of the seal by putting the block higher or lower. In this way, it will either remain longer within the cylinder, or, in the other case, above it, until the desired effortless mobility is achieved. In the end, the stroke must still be above 10 mm, though. If you do need to make a new seal, there is always reserve material.

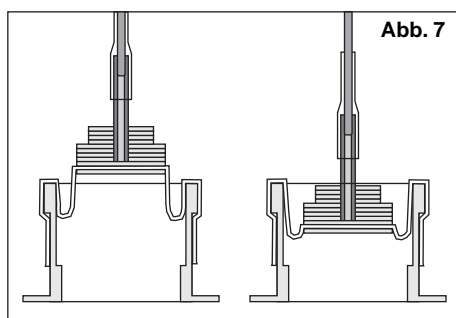

Step 31: Wrap several layers of thin sewing thread around the latex seal beneath the double edge of the working cylinder, in order to fix it in place and make it more airtight. Fold upward any portion of the seal that is too long. Now put the working piston on the hole in the main cylinder lid, in the position that it will be glued into, centre it and mark the outline of its ground plate with a pencil. This will be the gluing surface.

Abschnitt G:

Main Cylinder Final Assembly

Step 32: Cut off another 16 mm piece of silicone tube and push it 5 mm onto the brass tube of the displacement piston mounting, which points out of the centre of the main cylinder. Do as before – use one of the wire rods to help you by pushing it through from underneath. Push the silicone first onto the wire and next onto the tube. Pull out the rod.

Step 33: Put a sufficiently large cup or can on your desk and lay the main cylinder lid on it, so that the brass tube, with the silicone piece you just installed, points down into the cup. Now push the displacement piston rod into the end of the brass tube. The piston rod will enter until it is stopped by the silicone tube at the far end of the brass tube. The foam displacement piston will rest about 14 mm above the cylinder lid. Take the main cylinder base and put it on the displacement piston, with its glued-on cylinder wall facing down. Now push it downward until the edge of the cylinder wall touches the main cylinder lid below.

Important: The displacement piston must be positioned both low enough so that the cylinder wall can be glued on, and high enough so that it will under no circumstances come in touch with the two-component-glue that you will soon put to use.

Step 34: Turn the cylinder base so that the cylinder wall cardboard joints point in the desired direction – for example towards the circular segments of the cylinder lid. Arrange it until the cylinder wall shows an equal, symmetrical distance to all of the cylinder lid's edges. Check whether the piston inside shows roughly equal distance on all sides to the cylinder wall (3 mm) and does not touch anywhere. With a pencil, mark the outline of the cylinder wall on the lid, lift the wall off, sand the metal surface along and inside the line, as in step 6, and redraw the line afterwards.

Tip: The shape of the cylinder lid is not circular like the base, it is a circle blended with a square. It does have the same outer measurements, though, of 126 x 126 mm, and its circular sections match those of the base.

Step 35: Mix a sufficient amount of two-component-glue and apply a generous string on the cylinder lid, along and just inside the pencil line. This is where the cylinder wall touches the lid. Beware of any glue touching the displacement piston – the piston could get stuck inside and become immovable. Now carefully set the cylinder base on the lid, so that the edge of the cylinder wall dips into the glue. Turn the base a little so that the glue makes uniform contact with the wall. Check if the contact line of wall and lid is completely covered with glue. If necessary, apply glue to any gaps with a toothpick. Weigh the base down with a book if you like, and let the glue set well – after checking that the base hasn't moved and that the wall still shows equal distance to the outer edge of the metal on all sides. Airtight gluing connections between the cylinder wall, base and lid are a major prerequisite for the good functioning of the engine. Allow to dry well.

Step 36: Glue the base of the working piston over the hole in the working cylinder lid.

Important: Use plenty of glue so that the connection is really airtight. You will check for airtightness in the coming test. It is neither necessary nor sensible to attach the working cylinder to the main cylinder with two-component-glue. All-purpose glue bonds and seals the cardboard and aluminium well enough and offers an advantage: you can detach the cylinder from the metal with a sharp knife, if needed.

Test for airtightness: After the glue has set, you can test for leaks in the system. Take base and lid of the main cylinder between thumb and index finger and press both together, near the centre, with a quick, short squeeze. The air pressure inside rises and cannot escape but by pushing the working piston up. If the system is airtight, it will rise and stay there as long as you press. It will sink only as you let go. If it does not rise or stay up while you squeeze, there is a leak somewhere that you need to close. Any glued connection is in doubt (see also the trouble shooting section at the end of the manual).

Step 37: Pull the silicone tube off the brass tube in the centre of the main cylinder and push it up the displacement piston rod so that covers only its last 5 mm. The silicone tube's free end will later take the other half of the displacement piston rod, which is connected to the crankshaft. The tube connects the two to complete the displacement piston rod and also functions as a flexible joint. The other silicone piece on the brass tube of the working piston will not be removed, it stays the way it is.

First practical working trial: Set the main cylinder on a cup of boiling water, wait about 20 seconds until the base has heated up and then move the displacement piston up and down on its rod, just like the crankshaft will move it later during normal use. If the system is airtight, the working piston will jump up and down in the same rhythm, only staggered in time a little. This is another good opportunity to check the smooth running of the displacement piston rod and, even more important, of the latex seal in the working piston. If you do get the impression that you should replace the seal, this is the time to do it: dislodge the cardboard block with its brass tube from the latex seal, leaving only a thin cover of paper on the latex. Now cut a new cardboard disc for the inside and also a new latex seal. The rest is done according to the instructions in section E. Even though it is still possible to replace the seal later on, the working cylinder will not be as easily accessible as it is now.

Section H: The Stands

Step 38: Glue the middle pieces of stand 1 (G1 and G2) with their backs against one another. Take care that the edges fit exactly. If necessary, you can lightly press the parts while they dry, to make them perfectly plane.

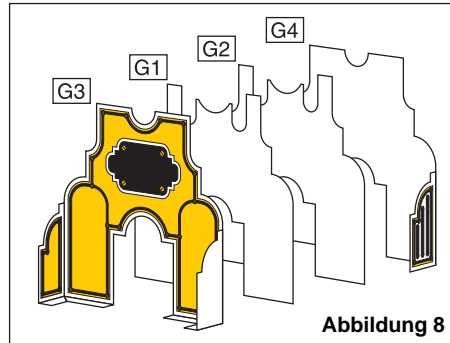

Step 39: The folding line of the inner piece of stand 1 (G3) are marked with little cuts. As mentioned in the introduction, the fold will be better if, in addition to the cuts, you indent (do not cut!) a line in the cardboard with a ruler and a tool - a blunt knife, for example. Fold forward along all of the groove lines. Now, do not apply glue to the inner piece (G3), but rather to one side of the middle piece (G1 + G2), and glue this onto the unprinted side of the inner piece. Again, line up the edges with care.

Tip: The reason for applying glue to the middle instead of the inner piece is that no glue should enter the gaps at the upper edge of the middle piece, which the inner and outer parts do not have. After gluing, these pieces form one semi-round and two long sockets for the crankshaft axle bearing discs and the plug-like feet of the axle bearing frame.

Step 40: Indent the fold lines of the outer pieces of stand 1 (G4) also and fold both side supports backwards. Once again, apply glue to the middle part and glue it onto the unprinted back of the outer piece, edges aligned.

Step 41: Last, glue both side supports of the inner and outer parts together, so that they will be perpendicular to the stand after drying, with the edges matching exactly.

Step 42: In the same way, build the second stand from parts (G5 to G8) and write your name in the designated space.

Section I: Handle and Stand Assembly

To determine the correct distance for gluing the stands straight away, it is necessary to assemble the handle first.

Step 43: Glue the backs of the handle's middle pieces (H1, H2) together and then glue one of the outer pieces (H3, H4) onto each side. Again, line up the edges well.

Tip: The two slots on the lower left and right are exactly 2 mm wide (4 layers of cardboard), and will be glued into the matching slots of the axle bearing frame later on in section M.

Step 44: Put up the two stands in such a way, that the two wing supports face each other. Without any glue, slip the handle's downward slots over the semi-round indentations at the top of the stands. This way, the stands will have just the right distance from each other that they need later on. For now, set them on the lid of the main cylinder, without glue. The distance between the aluminium edge and the outside of the stand has to be exactly 10 mm – on the side where the working cylinder is. On the opposite side, the distance is 31 mm (see ill. 9). It is larger on this side because this is where the flywheel will be turning. You can put the stand which has the owner's name on it on this side, too; but this is up to you to decide. Now the handle should be right over the centre of the working cylinder.

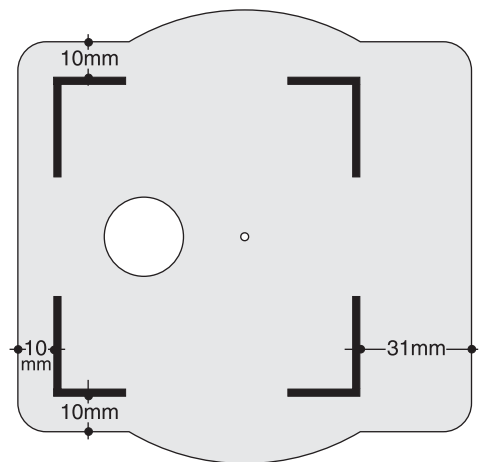

Step 45: Draw gluing lines on the aluminium with pencil and set square. Distances are as described above – 10 and 31 mm from the metal's edge. Glue the stands on in this position. The support wings are equally far from the sides. Allow to dry well.

Tip: In this case, too, all-purpose glue is fine for gluing the stands. If the connection should loosen or need to be undone, i.e. for repairs, you can easily reglue it anytime. You may also want to roughen the metal gluing surfaces a bit with sandpaper. The glue will bond even better.

Abschnitt J: Working And Displacement Piston Axle Bearings

The axle bearings for the two pistons (see ill. 10) are built of four layers of cardboard. Their middle parts each carry an axle bearing disc and a piston rod. The pre-punched lines of the slot that will take the piston rod and its hook lie very close to one another. They are not punched all the way and need to be cut with a knife.

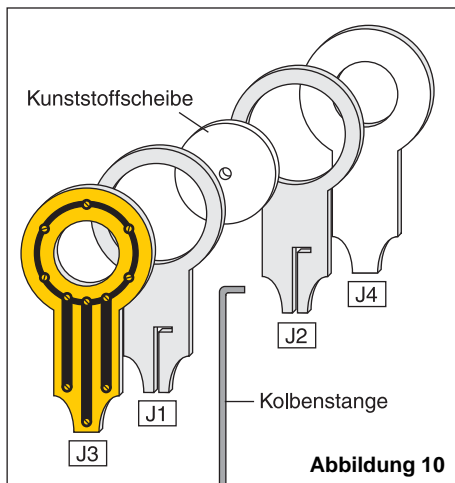

Step 46: Remove the 20 mm wide disc from the round head of the two middle parts (J1 and J2) of the working piston axle bearing and take out the slim cardboard bit from its neck. Remove the small cardboard disc from the outer part (J3), and glue first one and then the other middle piece onto its unprinted back. Put glue into the round depression in the axle bearing head and insert one of the 4 PVC axle bearing discs. Put glue and insert one of the two remaining piston rods into the small slot, fitting the hook at the end of the wire into its counterpart in the cardboard slot. Onto this, glue the second outer piece (J4).

Step 47: Repeat the procedure with parts (K1 to K4), which form the displacement piston axle bearing.

Section K: Crankshaft Axle Bearing Frames

The frames for the crankshaft axle bearings have a slot at the top, which matches the slots in the handle. In their centre they have a semi-round pocket, similar to the one at the top edge of the stands. At their bottom are two long, rounded plugs made of two cardboard layers, which will anchor the frames in the stands. No glue should enter the pockets or touch the plugs.

Step 48: Glue the middle pieces of the axle bearing frame (L1 and L2) with their backs against one another. Now apply glue to one side, but only to the grey gluing area and not to the plugs. Onto this, glue the inner part of the frame (L3). Glue the outer part (L4) onto the other side. No glue should run into the semi-round pocket.

Step 49: Repeat the procedure with the parts of the second frame (L5 to L8).

Step 50: After drying, check whether the frame plugs fit well into their sockets in the stands. Turn the frames to match the design of the stands.

You have now assembled all of the cardboard parts of the kit except for the outer wall of the working cylinder. You can start with the final assembly of the Stirling engine now.

Section L: Crankshaft Assembly

Step 51: Cut off eight 5 mm long pieces of silicone tube. Also put the following parts within reach: the two remaining axle bearing discs, the eight small guiding discs, the working piston and displacement piston axle bearings with their built-in piston rods, and the crankshaft. It has two rectangular projections, 22mm long and 4 mm wide, which are set off by 90°, and its ends are of unequal length: 45 and 22 mm.

Tip: The axle bearing discs and the axle bearings of the two pistons will all be mounted on the crankshaft in the following succession (see ill. 11): the axle bearing disc/axle bearing is in the middle, with a small guiding disc on either side, followed by a silicone tube segment on each side. This assembly group, consisting of (tube > guiding disc > axle bearing disc < guiding disc < tube), enables you to fix an axle bearings location at any point on the crankshaft. The silicone tubes can easily be moved with your fingers, but they will not dislodge of their own accord afterward. The guide discs, which are loose and turn freely, prevent the large axle bearing discs from touching the silicone and being slowed down by it.

Step 52: Push one of the silicone pieces over the short end of the crankshaft, around the two bends and onto the first projection. Now slip a small guide disc on the crankshaft, then the working piston axle bearing with its piston rod, next another guide disc and finally another silicone piece, all from the same end (see ill. 11). Move the whole assembly group until it rests in the centre of the projection. The guide discs should be just close enough to the axle bearing disc to still turn freely.

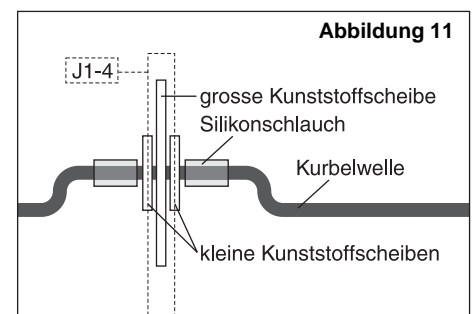

Important: The axle bearing needs just enough leeway to be able to turn freely and without friction. Do not confuse the two axle bearings. Here's how to tell them apart: the working piston bearing, which you have just installed, has an overall length of 76.5 mm, including rod. It is 7 mm longer than the displacement piston bearing, which is 69.5 mm long and will be installed in the next step.

Step 53: From the long end of the crankshaft, assemble the second axle bearing group on the other shaft projection; this time with the displacement piston bearing in the middle. Adjust this group in the same way until the bearing is in the centre of the projection and still turns freely.

Step 54: Assemble a similar group on each of the two straight ends of the crankshaft with the two remaining axle bearing discs serving as centres. The outer silicone piece is positioned almost at the end of the short side of the crankshaft – the wire shows only for a few millimetres. At the long end of the shaft, push the group far enough for the axle bearing disc to have a distance of about 83 mm to the other axle bearing disc at the short end.

Step 55: Now insert the two axle bearing discs into the pockets at the top edge of the stands. Check if all of the discs will turn freely and whether the working and displacement piston axle bearings are positioned directly above their respective brass tubes below. Where needed, move and adjust the groups.

Step 56: Lift the axle bearing discs, together with the crankshaft, out of the stands once more. Before you insert them again, push the working and displacement piston rods into their matching silicone tubes. Do this by taking the tube into one hand and turning the bearing back and forth a little, so that the wire slips into the silicone.

The Working Piston Rod: It needs to descend enough to also enter the brass tube that is connected to the latex seal. To keep from twisting the latex when turning the axle bearing to and fro, it is best to grip the brass tube with a pair of small pliers or strong tweezers (or with your fingertips). Take care that the bearing is not slanted in respect to the crankshaft.

The Displacement Piston Rod: This rod enters the tube just far enough so that about 5 mm of distance remain between its end and the end of the displacement piston rod coming from below. Since the displacement piston turns freely, the axle bearing cannot tilt – the piston will always follow the turning motion. In case the foam disc is not quite parallel to the main cylinder base and lid, you can try to compensate by twisting the displacement piston a little in relation to the axle bearing.

Step 57: Next, insert the plugs of the axle bearing frame into their matching sockets in the stands. They now hold the upper half of the axle bearing discs and will give them firm support. It is self-evident from the design, which side faces out and which one in.

Tip: There is no need to glue the plugs into their sockets; the friction between the cardboard surfaces will suffice. In any case it would not make sense, since this way it is easy to take the engine apart if you should need to adjust or repair something.

Abschnitt M: Handle And Flywheel Assembly

Step 58: See if the handle's slots will fit completely into the slots at the top of the axle bearing frames. Then glue the handle into place.

Step 59: Take the flywheel and apply a bit of glue to the hole in the tri-star axle mounting. Then push the flywheel, mounting first, onto the free end of the crankshaft.

Tip: The bond between the thin crankshaft wire and the cardboard is not a very strong one, but the friction between the two is quite sufficient for the engine's needs. This way the flywheel can also be dismounted easily from the crankshaft, if needed.

Abschnitt N: Fine Tuning And First Trial Run

Have a little patience! Like any other engine, this Stirling engine needs to be fine tuned in order to run without trouble. Don't be disappointed if you do not succeed with the first try. It took Robert Stirling years before he was able to present his first engine!

Step 60: Set the crankshaft slowly in motion by turning the flywheel. Both shaft projections will show a stroke of 8 mm in the course of one complete revolution (4 mm upward, 4 mm down). Check whether the length of the working piston rod is correct and adjust, if necessary, by holding on to the brass tube with your pliers again and turning the axle bearing. The working piston should follow the up-and-down motion of the crankshaft without tensing the latex seal in either the upward or downward position – otherwise it would slow down the crankshaft motion. On the other hand, the latex should not form a bulge either, that works against the movement and snaps when the working piston passes it.

Important: Take plenty of time to find the optimum position for the working piston, meaning the ideal position in or above the working cylinder – the one causing the least resistance. If needed, you may also have to shift the latex seal a bit once more to increase or decrease its leeway. Finally, make sure that the axle bearing has not twisted on the crankshaft.

Step 61: The displacement piston, too, has a stroke of 4 mm upward and 4 mm down. The displacement piston's foam disc has a height of 8 mm in itself, so it has a total mobility range of $8 + 4 + 4 = 16$ mm; this is 2 mm less than the interior height of the main cylinder. This is why the distance from one piston rod end to the other within the silicone tube has to be adjusted so that the displacement piston hits neither lid nor base of the cylinder during a full revolution. Ideally, the foam disc's edge should not touch the aluminium either at its highest or at its lowest point. Under no circumstances, though, should the cardboard mounting in the centre of the displacement piston touch the cylinder lid or base; this would cause massive braking.

Test: *Very carefully and delicately, turn the flywheel. You will be able feel whether the displacement piston is still giving any resistance at either its highest or lowest point. Check also if the displacement piston twists and swings along at the high and low point, when you move the axle bearing back and forth. If so, this is a good indication that it still keeps a bit of distance to the aluminium at these positions. See if the silicone tube segment is not too long. It should not touch the brass tube.*

Step 62: Use a toothpick to apply a small drop of oil in the gap between the displacement piston rod and the brass tube. This will make it completely airtight. You can also apply some oil to all the places where an axle bearing disc touches the crankshaft or a neighbouring guide disc, to reduce friction.

Last Check before Take-Off: *Inspect the two axle bearings to see if they are exactly above the working and displacement pistons, and that they are not tilted. Check the crankshaft to see whether it can be moved back and forth a fraction of a millimetre in its two axle bearing discs and is not slowed down by them, etc.*

Important: *Children should not run the Stirling engine without adult supervision. Even if the amount of hot liquid in a cup is not so large, it is enough to cause very unpleasant scalds.*

Step 63: Fill a large cup with boiling water and set the engine on it. Wait about half a minute until the base of the main cylinder is hot, and give the flywheel a soft turn. You will notice that it is easy to turn only to the left side; turned to the right, it will soon brake. If everything is tuned well, the engine will turn faster and faster until it reaches the optimum speed in relation to the current temperature difference between the cylinder base and lid. It will then slow down, but only very little.

The engine runs? *Congratulations! If your tuning went well at the first go, the engine should run for about 20 minutes. If you are happy with the result, go on to step 64 and glue on the outer wall of the main cylinder. Perhaps you would like to fine-tune your engine, though – running times of more than one hour have already been achieved! In this case you should postpone step 64 and try all the possibilities mentioned before and also in the following tips.*

Step 64: Bend the outer wall for the working cylinder (E5) and its connecting piece (E6) by pulling them over an edge or rolling them around a thick marker pen. Glue the connecting piece halfway on to one end of the outer wall, only just enough to cover the grey gluing area. Now wrap the wall around the working cylinder and glue the connecting piece to the other side in such a way that the wall can still be lifted and removed without trouble, if needed. Do not glue it to the cylinder; it only serves as a cover for the latex seal and its thread. Now bend the decoration (E7) and glue it on the opposite side of the cylinder wall, symmetrical to (E6).

Section O:

Tuning Tips:

Extending the Running Time & Alternative Energy Sources

A few ideas for prolonging the running time of the Stirling engine after you have fine-tuned all you can, and about using solar energy as a heat source:

- Use a larger cup and pre-heat it.
- Put the engine on a thermos with large content and a big enough opening.
- Set the engine over a tea warmer candle. Beware: do not overheat! It is best to put a buffer in between (a metal plate or a tile).
- Take the metal containers from two tea warmer candles, fill them with ice cubes, and put them on the lid of the main cylinder, between the stands. This will increase the temperature difference between lid and base, which, in turn, will extend the running time.
- Set the engine on a cold source, i.e. a cooling pack from the freezer or a thick block of ice. Since the temperature difference between the two aluminium plates equalizes in the opposite direction, the flywheel also will need to spin the other way.
- If the outside surface of the plates is painted black (see step 4), they will absorb, and also emit, heat better.
- The black paint also enables you to use solar energy for running the engine: with the help of a mirror, focus the sunlight on the base. To be successful, you need strong sunlight - as in the middle of summer or at noon, or combining both - as well as some shade on the lid, which should be as cool as possible.
- Balance the flywheel by applying paper clips on one side. Or try gluing together some of the leftover cardboard pieces from the flywheel and pushing them into 2 or 3 adjacent empty spaces on the wheel. Now twist the flywheel on the crankshaft until the engine runs smoothest

If the engine runs only for a short time or not at all:

Take your time to check the possible error sources calmly and one by one. Basically there are only two kinds of causes to deal with; each one by itself or both together can be responsible.

One possible cause: leaks

- Is there a leaking spot somewhere along the glue lines of the main cylinder? Usually, you can see whether there are any gaps in the glue between the cylinder wall and the lid or base – you can also try looking with a magnifying glass. If you press the plates together and move your mouth along the glue lines, your lips, being very sensitive, will detect any gaps that allow air to escape. If you find gaps, close them with normal or two-component-glue.
- Is there a leak where the working cylinder and its cardboard base are connected? A pinhead-sized hole would already be enough! Since the pieces are connected on the inside by a ring of gluing teeth, there might be a gap between two of the teeth that wasn't closed well with glue in section D. If so: fill the gap from outside with glue.
- Does the bond between the working cylinder base and the aluminium plate leak? This is not very likely, but still possible. If this is the case, either seal the outer edge with glue (not so pretty, though) or remove the working cylinder carefully with a knife and reglue (you may need to remove the stands for better access).
- Are there any leaks between the working cylinder and the latex seal? If so, retie and reinforce the thread and also check that no air can escape via the cardboard joint in the cylinder wall.
- Perhaps the drop of oil is missing that seals the gap between the displacement piston rod and the brass tube it enters? If so, seal it now.
- If nothing seems to help and there is still a leak somewhere: remove the stands, push the displacement piston's silicone tube down until it slips over the brass tube, forming an airtight seal, and pull the working piston with its latex seal all the way up. Now do the leak search with your lips once more. If you find nothing, take a small paint brush and cover the likely places with soapy water and move the working piston up and down until bubbles indicate the leak. If you dry off the cardboard quickly and it will suffer no harm.

The other possible cause: friction

- Perhaps the working piston has to overcome too much resistance in moving up and down? If so: push the latex seal either up or down and see where the working cylinder runs with the least effort – deeper down in the cylinder or higher above it – and to what extent the latex is freely movable or not. If necessary, redo the latex seal.
- Maybe there are remnants of glue on the free-moving part of the latex seal, which have made the material inflexible. If so: redo the latex seal.
- The working piston rod might be either too far, or not far enough, inside the working piston, keeping it from moving up and down easily. If so: correct the distance as described in step 60.
- The axle bearing of the working piston may be tilted in relation to the crankshaft. If so: turn the piston wire within the brass tube of the working piston accordingly.
- Is the displacement piston stuck or glued in the main cylinder? If so, there is only one thing to do: remove the working piston, or, if necessary, the whole working cylinder, and try to free the displacement piston through the plate's hole.
- Were the two axle bearings plus piston rods confused? If so: switch them. A reminder: the longer one is located above the working piston.
- Is the silicone joint positioned too far down on the displacement piston rod, making it touch the brass tube? If so, correct it.
- Perhaps the overall length of the two displacement piston rod wires is either too short (piston hits lid) or too long (piston hits base). If so, correct as described in step 61.
- Is there too much friction between any of the four axle bearing discs on the crankshaft? If so, shift the small silicone pieces until the bearings all have sufficient room. All crankshaft bearings should be lubricated.
- Check whether the two axle bearings plus piston rods are exactly above their respective cylinders. If not, shift the silicone pieces accordingly.